

AquaScan Registration Unit CSE3150

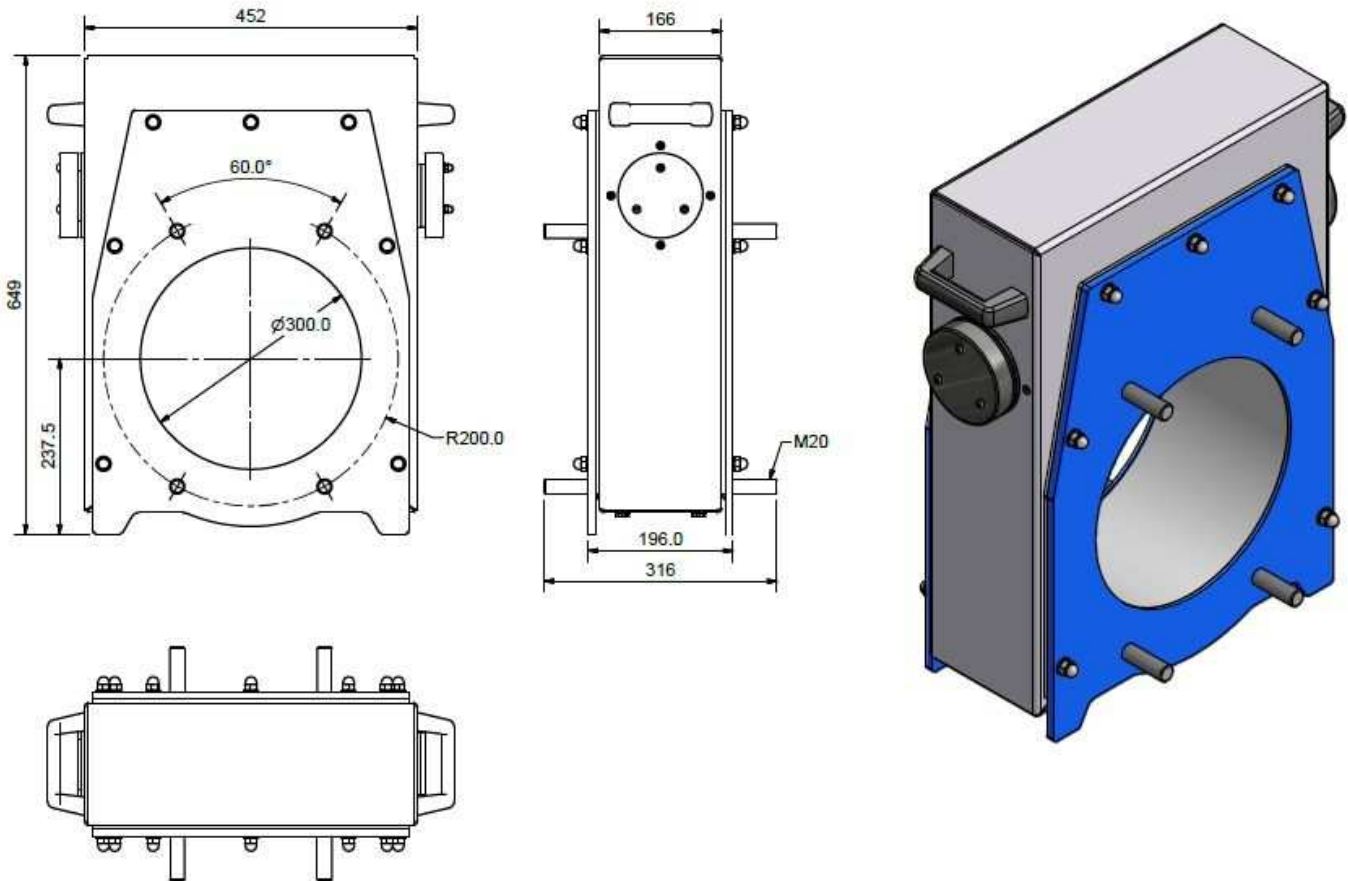

Material	<i>Powder painted aluminium and POM</i>
Weight	<i>26 Kg</i>
Dimensions	<i>649 x 452 x 316mm</i>
Capacity	<i>25 tonnes/unit/hour (1Kg)</i>
Power Consumption	<i>15W</i>
Power supply	<i>Powered by the Control Unit</i>
Flange connection	<i>DN300</i>
Fish size	<i>3g to 12Kg</i>
Accuracy	<i>98-100%</i>
Arrangement	<i>Approx. 30 ° tilt forward. 0 to ¼ pipe transport water</i>
Flow speed	<i>2,5 - 3 m/s</i>
Standard cable length included	<i>10 meters</i>
Requirements	<i>AquaScan Control Unit</i>