

AquaScan Registration Unit CSE3500

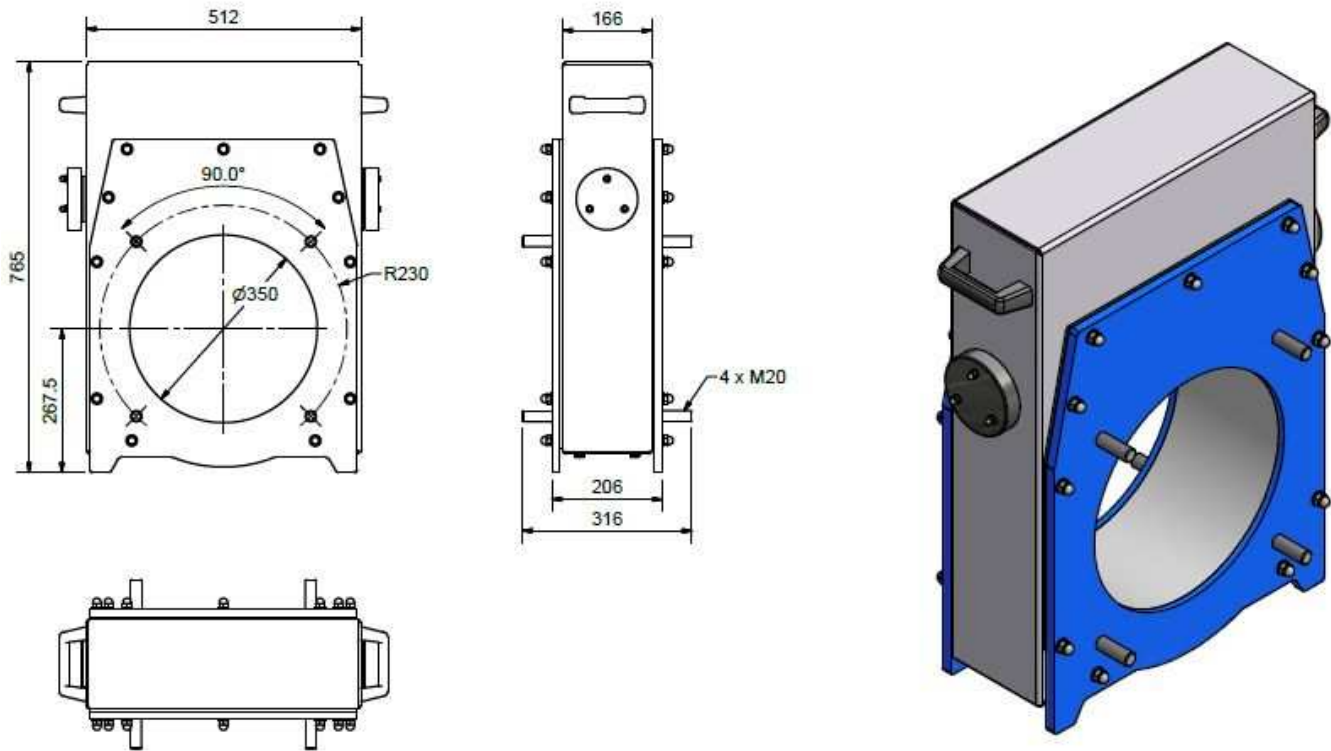

Material	<i>Powder painted aluminium and POM</i>
Weight	<i>32 Kg</i>
Dimensions	<i>765 x 512 x 316mm</i>
Capacity	<i>30 tonnes/unit/hour (1Kg)</i>
Power Consumption	<i>17W</i>
Power supply	<i>Powered by the Control Unit</i>
Flange connection	<i>DN350</i>
Fish size	<i>10g to 18Kg</i>
Accuracy	<i>98-100%</i>
Arrangement	<i>Approx. 30 ° tilt forward. 0 to ¼ pipe transport water</i>
Flow speed	<i>2,5 - 3 m/s</i>
Standard cable length included	<i>10 meters</i>
Requirements	<i>AquaScan Control Unit</i>